

A New Fault Tolerant Nonlinear Model Predictive Controller Incorporating an UKF-Based Centralized Measurement Fusion Scheme

Salahshoor, Karim⁺; Salehi, Shabnam*

Department of Automation and Instrumentation, Petroleum University of Technology, Tehran, I.R. IRAN

ABSTRACT: A new Fault Tolerant Controller (FTC) has been presented in this research by integrating a Fault Detection and Diagnosis (FDD) mechanism in a nonlinear model predictive controller framework. The proposed FDD utilizes a Multi-Sensor Data Fusion (MSDF) methodology to enhance its reliability and estimation accuracy. An augmented state-vector model is developed to incorporate the occurred sensor faults and then a UKF algorithm is utilized to estimate the augmented state vector including system states along with the fault terms using a centralized measurement fusion scheme. The designed FDD architecture is then merged with a conventional NMPC to form a Fault-Tolerant Control System (FTCS). A series of sensor fault scenarios is conducted on a Continuous Stirred Tank Reactor (CSTR) to comparatively illustrate the superiority of the proposed FTCS in eliminating the miserable impacts of the induced sensor faults against a conventional NMPC.

KEY WORDS: Fault Tolerant Control System (FTCS), Nonlinear Model Predictive Controller (NMPC), Fault Detection and Diagnosis (FDD), Unscented Kalman Filter (UKF), Multi Sensor Data Fusion (MSDF).

INTRODUCTION

The ever-increasing complexity of modern chemical plants and the tightly environmental regulations are pushing the process industries to optimize their production systems against any process abnormality. Any malfunction in these plants will cause great economic losses or may even result into safety dangers [1]. The preventive action should be done by the control mechanism, creating a Fault Tolerant Control (FTC) system. If the designed mechanism operates correctly, the system function is satisfied even after occurrence of a fault, possibly after a short time period of performance degradation.

Model Predictive Control (MPC) has found successful applications, especially in the process industries. The novel characteristics of MPC have encouraged the researchers to merge it with the FDD methods to develop FTC systems. *Maciejowski* [2] was among the first one to utilize MPC in FTC systems. *Pranatyasto et al.* [3] introduced a PCA-based FTC system with MPC to control a simulated Fluid Catalytic Cracking (FCC) unit. *Prakash et al.* [4] have developed a Fault Tolerant Control System (FTCS) based on the Generalized Likelihood Ratio (GLR) and a standard MPC controller for a simulated, nonisothermal CSTR system.

* To whom correspondence should be addressed.

+ E-mail: salahshoor@put.ac.ir

1021-9986/11/4/107

6/\$2.60

In this work, a new automated FDD system has been proposed based on an UKF estimator. The proposed methodology utilizes a Multi-Sensor Data Fusion (MSDF) technique to enhance the accuracy and reliability of state estimation. The developed FDD system is then merged with a Nonlinear Model Predictive Controller (NMPC) to design a FTC system. A variety of simulation test studies has been carried out to illustrate the performances of the proposed FTC system in a CSTR against various sensor faults.

THEORETICAL DEVELOPMENT

FDD System

A deep review on the subject of FDD methods is presented in [5]. In this paper, a FDD approach is proposed by incorporating a KF-based multi-sensor data fusion methodology to detect and estimate the occurring sensor faults in chemical process plants. For this objective, a measurement fusion scheme is utilized in which the sensor measurements are first fused to provide an augmented state vector including the bias terms. A set of most commonly appearing faults in the sensors, i.e. calibration and aging or wearing biases, is examined and an UKF-based Centralized Measurement Fusion (CMF) technique is used to estimate these faults. The estimated states, including the system states and the estimated sensor faults, are finally incorporated in a FTC framework utilizing the NMPC approach.

Unscented Kalman Filter

The Kalman filter addresses the general problem of trying to estimate the state $x \in \mathfrak{R}^n$ of a discrete-time controlled process, governed by the following linear stochastic difference equation:

$$x_k = Ax_{k-1} + Bu_{k-1} + w_{k-1} \quad (1)$$

with a measurement $z \in \mathfrak{R}^n$ that is:

$$z_k = Hx_k + v_k \quad (2)$$

The random variables w_k and v_k represent the process and measurement noise, respectively. They are assumed to be independent of each other, modeled by a white signal having normal probability distributions with covariances Q_k and R_k , respectively. In most practical applications of interest, however, the process dynamics and the measurement equations obey the following non-linear relationships:

$$x_k = f(x_{k-1}, u_k, v_k) + w_{k-1} \quad (3)$$

$$z_k = h(x_k, k) + v_k \quad (4)$$

Where f and h indicate known nonlinear functions.

Julier & Uhlmann [6,7] developed the UKF algorithm which does not require to linearize the foregoing general nonlinear system dynamics. The UKF algorithm can be found in different literatures such as [8].

KF-Based Measurement Fusion Approach

There are essentially two methods for measurement fusion. The first simply merges the measurements into an augmented observation vector and the second combines the measurements using minimum mean square estimates [9]. In this paper, the first measurement fusion technique has been used. In this method, the measurement vectors z_k^1 and z_k^2 , obtained from two (or more) sensors, are merged into a new augmented measurement vector given by:

$$Z_k = [(z_k^1)^T \quad (z_k^2)^T]^T \quad (5)$$

Denoting:

$$H(x_k, k) = \left[(h^1(x_k, k))^T \quad (h^2(x_k, k))^T \right]^T \quad \text{and}$$

$$V_k = \left[(v_k^1)^T \quad (v_k^2)^T \right]^T,$$

Eqs. (4) and (5) can then be formulated into a new measurement equation, given by:

$$Z_k = H(x_k, k) + V_k \quad (6)$$

Based on the assumed statistical independence of the two sensors, the covariance matrix R_k for the merged measurement noise V_k can be defined as:

$$R_k = \begin{pmatrix} R_k^1 & 0 \\ 0 & R_k^2 \end{pmatrix} \quad (7)$$

Therefore, the estimate, $\hat{x}_{k|k}$, of the state vector can be determined via the UKF using the above equations.

Fault Modelling Procedure

To carry out the sensor fault detection due to calibration, a method is required to quantify the state deviation. For this purpose, the following stochastic Auto-Regressive (AR) model is employed to explain the time evolution of the sensor bias as extra process state variables:

$$b_k^i = b_{k-1}^i + N_k^{bi} \quad i = 1, \dots, n_b \quad (8)$$

Where n_b denotes the number of faulty sensors, and N_k^{bi} indicates a zero-mean white Gaussian noise with covariance matrices Q_k^{bi} . Using the above model for sensor bias faults, a new augmented state variable vector $x_k^* = [b_k^T \quad x_k^T]^T$ is developed by considering the sensor faults as additional state variables. This assumption changes the nonlinear model formulations in Eqs. (3) & (6) to the following nonlinear augmented state model:

$$x_k^* = F(x_{k-1}^*, u_k, v_k) + w_{k-1}^* \quad (9)$$

$$z_k^* = H(x_k^*, k) + v_k \quad (10)$$

where

$$F(x_{k-1}^*, u_k, v_k) = [b_{k-1}^T \quad f(x_{k-1}, u_k, v_k)] \quad (11)$$

$$w_{k-1}^* = [N_k^{bi} \quad w_{k-1}]^T \quad (12)$$

$$H(x_k^*, k) = [0 \quad H(x_k, k)] \quad (13)$$

NMPC Approach

Since most of the chemical processes are highly nonlinear, nonlinear extensions to MPC (NMPC) must be applied in order to provide satisfactory control results. To alleviate the derivation of control law, the following objective function, formulated in vector notation, can be considered for computing the desired control moves [10]:

$$J(k) = \sum_{p=N_1}^N \|y^{sp}(k+p|k) - y(k+p|k)\|^2 + \lambda \sum_{p=0}^{N_u-1} \|\Delta u(k+p|k)\|^2 \quad (14)$$

Where y^{sp} denotes the reference or the desired output vector and $y(k+p|k)$ is the vector of output predictions. The tuning parameters of the controller are N_1 , N , N_u , and λ . N_1 is called the minimum cost horizon, N the prediction or maximum cost horizon, and N_u the maximum control horizon. λ denotes a weighting factor, penalizing changes in the control inputs.

There are several well-known algorithms to solve the foregoing NMPC optimization problem. A gradient descent method doesn't generally have fast convergence and hence cannot be used in real time applications. Thus, only Newton

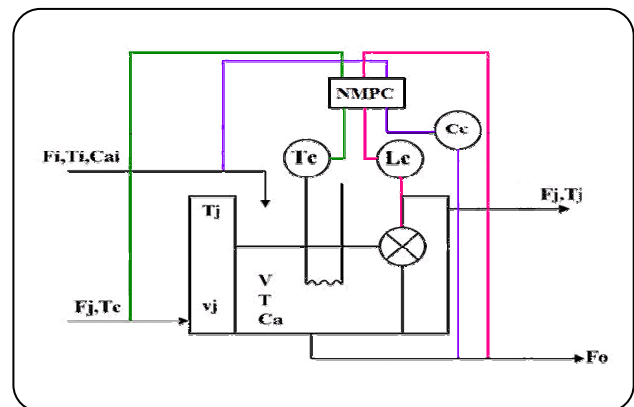

Fig. 1: Continuous Stirred Tank Reactor.

or Newton-related methods should be considered as proper candidates [10]. A full Newton method, however, involves the calculation of the Hessian matrix which is difficult when the control and prediction horizons become larger than one [10]. The quasi-Newton algorithm is suitable when the Hessian matrix is difficult to be derived. In fact, a positive-definite approximation to the inverse Hessian matrix can be constructed in quasi-Newton approach [11].

Quasi-Newton Approach

In order to determine the minimum, it is necessary to apply an iterative search method, specified as follows:

$$U^{(i+1)} = U^{(i)} + \mu^{(i)} f^{(i)} \quad (15)$$

$U^{(i)}$ defines the current iterate of the sequence of future control inputs, $\mu^{(i)}$ indicates the step size, and $f^{(i)}$ represents the search direction. The Newton search direction is given by:

$$f^{(i)} = -B^{(i)} G(U^{(i)}(k)) \quad (16)$$

Where $B^{(i)}$ specifies the inverse Hessian and $G(U^{(i)}(k))$ is the gradient of the cost function with respect to the unknown control inputs. The quasi-Newton method approximates the full Newton search direction, $B^{(i)}$, according to the information embedded in the previous evaluations of gradient and criterion [10].

CSTR Plant Description

The CSTR plant, represented schematically in Fig. 1, works under atmospheric pressure [12]. It is, in fact, a cooling water-jacketed reactor which involves an irreversible and liquid phase exothermic reaction $A \rightarrow B$

Table 1: Fault scenario.

Sensor fault parameter	The magnitude of the fault	
	V	Ca
Bias	6	0.05

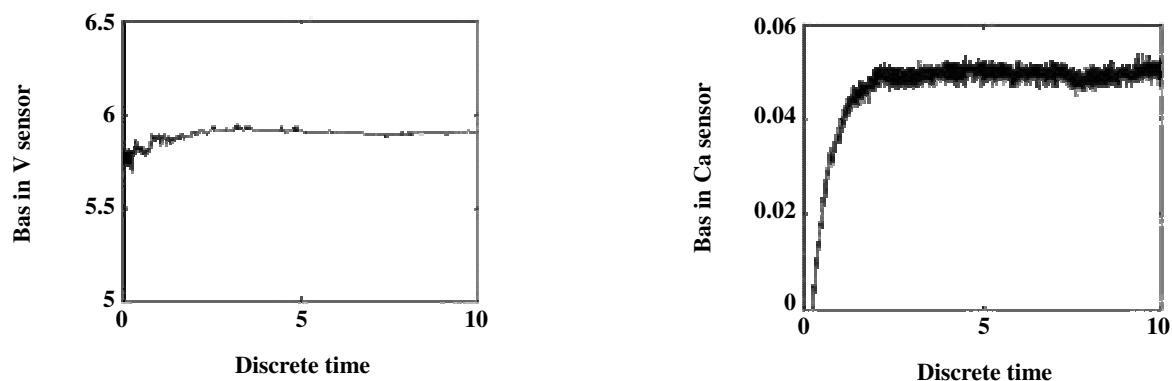

Fig. 2: Estimating the introduced calibration biases via the CMF-based FDI mechanism.

taking place inside the reactor tank. Negligible heat losses, constant densities, perfect mixing inside the tank and uniform temperature in the jacket are assumed.

An NMPC controller is used to regulate the reactor outlet temperature (T), the liquid volume (V) inside the reactor tank and the output concentration (Ca) via jacket flow rate ($u_1=F_j$), outlet flow rate ($u_2=F_o$) and the inlet flow rate ($u_3=F_i$), respectively. The dynamic equations describing the system along with the values of process parameters and steady state conditions are given in [12].

SIMULATION STUDY

MATLAB together with its SIMULINK facilities have been employed to perform the organized simulation test studies. The basic time unit is hours (h) and the sampling time is taken to be equal to 0.0025 h.

A fault test scenario is conducted on the process in which two CSTR key measured variables (V , Ca) are corrupted with the corresponding sensor faults. First, the effectiveness of the designed FDD in estimating sensor calibration biases is studied. The introduced calibration biases are summarized in Table 1.

The designed FDD utilizes an Unscented Kalman Filter (UKF) to estimate the fused measurement state vector including the bias terms. The controller uses these estimates to obtain the compensated sensor measurements and hence keep the controlled variable near its

desired trajectory. Fig. 2 illustrates the ability of the proposed FDD in estimating the induced sensor biases in the process, while Fig. 3 compares the performance of the designed FTC system against a conventional NMPC controller.

In the next study, aging biases are considered. The following fault scenario is introduced artificially in the plant to investigate the ability of the designed FDD mechanism in estimating the occurred aging biases. These biases have a zero value in the beginning of the simulation run but at $t=5$ and 6 they start increasing with a constant slope until they reach their final values. The organized test studies were conducted similar to the calibration bias case using the proposed FDD procedure. Fig. 4 illustrates the satisfactory performance of the designed FDD architecture in detecting and identifying the introduced sensor biases in the plant. Fig. 5 comparatively demonstrates the performance of the proposed FT-NMPC against a conventional one in the presence of aging biases.

The elapsed time during the calculation of control action in each time step is an important issue which should be considered in the design of a FTCS. The average calculation time in the case of calibration and aging biases is equal to 0.0115 s and 0.0107 s with a standard deviation of 0.0056 and 0.0056, respectively, which is much less than the sample time (0.0025 h = 9 s).

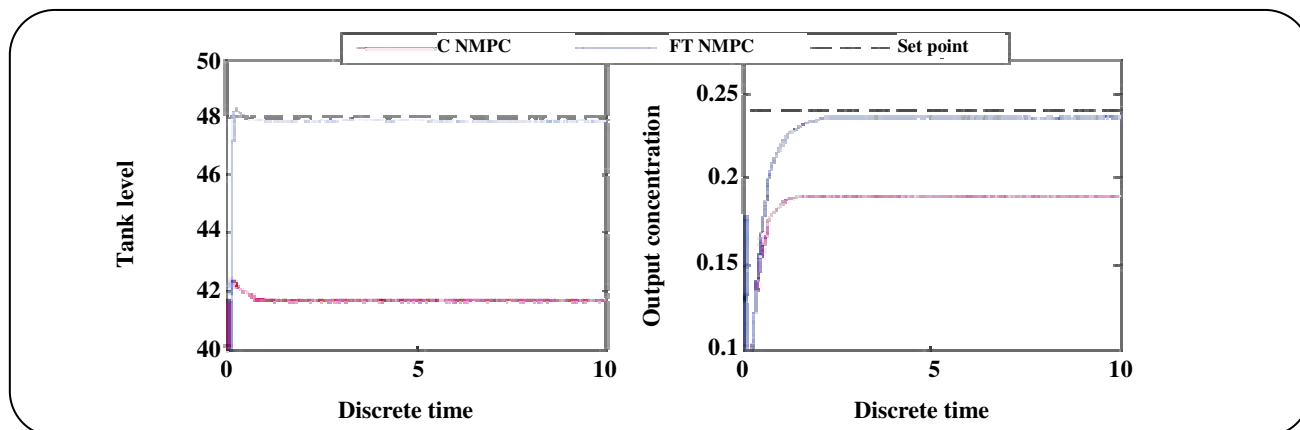

Fig. 3: Performance of the proposed FT NMPC against a conventional NMPC.

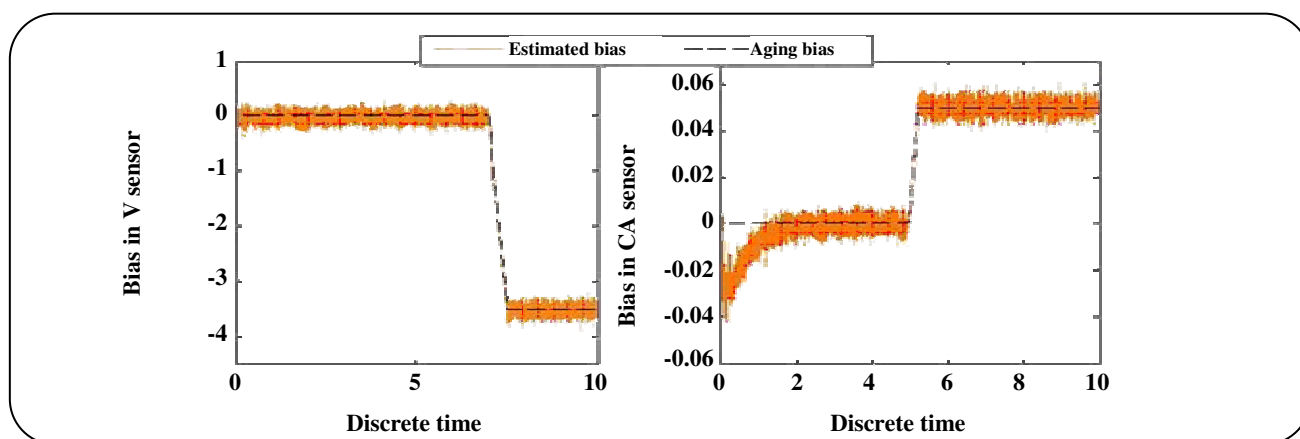

Fig. 4: Estimating the introduced aging biases via the CMF-based FDD mechanism.

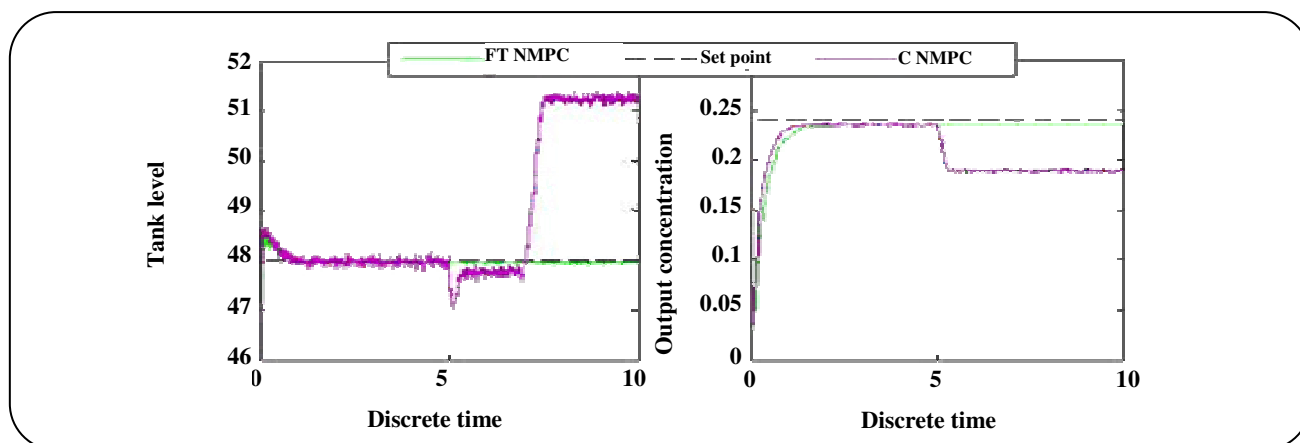

Fig. 5: Performance of the proposed FT- NMPC against a conventional NMPC.

CONCLUSIONS

In this paper, a new fault tolerant NMPC has been presented which incorporates a FDD mechanism. The proposed mechanism utilizes a MSDF architecture which fuses the sensor measurements in augmented state vectors

including bias terms to obtain a combined measurement vector. Then, a single UKF is used to obtain the final state estimates based upon the fused observations. The designed NMPC controller then uses the estimated fault information to compensate for the ill-measurements

and keep the controlled variables near their desired trajectories. The set of conducted sensor fault scenarios has illustrated the capabilities of the proposed controller to cope with the induced faults due to calibration and aging biases in a CSTR benchmark plant.

Received : Feb. 12, 2010 ; Accepted : Jan. 31, 2011

REFERENCES

- [1] Visscher, R., Chernobyl Nuclear Disaster. <http://www.chernobul.co.ul/hoef.html>, (1990).
- [2] Maciejowski J. M., Modeling and Predictive Control: Enabling Technologies for Reconfiguration, *Annual Reviews in Control*, **23**, p. 13 (1999).
- [3] Pranatyasto T.N., Qin S.J., Sensor Validation and Process Fault Diagnosis for FCC Units under MPC Feedback, *Control Engineering Practice*, **9**, p. 877 (2001).
- [4] Prakash J., Patwardhan S.C., Narasimhan S.A., Integrating Model Based Fault Diagnosis with Model Predictive Control, *Ind. Eng. Chem. Res.*, **44**, p. 4344 (2005).
- [5] Venkatasubramanian V., Rengaswamy R., Yin K., Kavuri S.N., A Review of Process Fault Detection and Diagnosis Part I: Quantitative Model-Based Methods, *Computers and Chemical Engineering*, **27**, p. 293 (2003).
- [6] Julier S.J., Uhlmann J.K., Durrant-Whyte H., A New Approach for Filtering Non-Linear Systems, in "Proceedings of the American Control Conference", p. 1628 (1995).
- [7] Julier S.J., Uhlmann J.K., A New Extension of the Kalman Filter to Non-linear Systems, in "Proc. Of AeroSense: The 11th Int. Symp. A.D.S.S.C", (1997).
- [8] Grewal M., Andrews A.P., "Kalman Filtering, Theory and Practice Using Matlab", Third Edition, John Wiley & Sons, (2008).
- [9] Harris C., Bailey A., Dodd T., Multisensor Data Fusion in Defense and Aerospace, *Journal of Royal Aerospace Society*, **162**, p. 229 (1998).
- [10] Sørensen H., Nørgaard M., Ravn O., Oulsen N.K., Implementation of Neural Network Based Non-Linear Predictive Control, *Neurocomputing*, **28**, p. 37 (1999).
- [11] Dennis J.E, Schnabel R.B., "Numerical Methods for Unconstrained Optimization and Nonlinear Equations", Prentice-Hall, (1997).
- [12] Luyben W.L., "Process Modeling Simulation and Control for Chemical Engineers", 2nd Ed., McGraw-Hill, (1989).